

Proposed Design of Small-Scale Wind Turbine to Run Low-Power Application for Humanitarian Aid



Air Breeze [1]

Devon Heston
Samantha Bonner
Pei Chan

ME 340 and ME 297, Spring 2018
Mechanical Engineering Department
Pennsylvania State University
22 April 2018

Proposed Design of Small-Scale Wind Turbine to Run Low-Power Application for Humanitarian Aid

Devon Heston
Samantha Bonner
Pei Chan

ME 340 and ME 297, Spring 2018
Mechanical Engineering Department
Pennsylvania State University
22 April 2018

Summary

This document proposes a small-scale wind turbine as a potential solution for the heat stroke epidemic in sub-Saharan Africa. In sub-Saharan Africa, rising global temperatures have caused the number of deaths due to heat stroke and other heat related illnesses to dramatically increase in recent years [2]. For sub-Saharan nations like Guinea, limited access to electricity makes the problem even worse, preventing most residents from using central cooling systems in their homes. With that in mind, our team will develop and test a small-scale wind turbine that can power a portable fan, improving in-home ventilation on as-needed basis. Since wind conditions can be unpredictable, our product will incorporate a battery back-up, allowing for consistent performance regardless of weather conditions.

Using well-established concept generation techniques, our team selected a design for the small-scale turbine that will power our cooling system. Our selected design uses a horizontal-axis configuration with three blades and a yaw bearing. That bearing will allow the blades to maximize wind currents, regardless of their direction. For durability, our bearing will interface with a metal post and weatherproof enclosure. Inside the enclosure, our motor assembly will incorporate a 3:1 gear ratio, optimizing the input range for a DC generator. By varying the number of blades and using different gear ratios within our calculations, we were able to see that having three blades and a 3:1 ratio allowed for the best efficiency and highest power output, which is why it was selected.

Moving forward, our team will develop an Alpha I prototype and improve upon its design in a second iteration. The initial prototyping process will take about four weeks. For the four weeks that follow, we will take what we learned from the Alpha II prototype and make additional improvements to the Beta model. While working on these prototypes, our team will draft a final report and presentation, which will be delivered in the final week of our project.

Contents

Summary	i
Statement of Problem	1
Proposed Design for Wind Turbine	2
Customer Needs and Accompanying Metrics and Specifications	3
Function Structure and System Decomposition	3
Concept Generation	5
Concept Screening and Selection	7
Efficiency Calculations	8
Management Plan	11
Appendix A: Concept Scoring Matrices by Sub-Function	13
Appendix B: AHP Matrix	15
Appendix C: Taguchi Analysis	16
Appendix D: Detailed Management Plan	18
References	19

Statement of Problem

According to the US. Agency for International Development (USAID), only 26% of Guinea's residents have access to electricity. In rural areas, this percentage drops to 11% [3]. Figure 1 summarizes these shocking statistics and shows their impact on generation capacity. Without reliable access to electricity, most of Guinea's residents cannot utilize modern appliances in their homes; and features, such as refrigeration and climate control, remain widely unavailable. As global temperatures continue to rise, particularly in sub-Saharan Africa, climate control within residential homes becomes an important priority. Writing for the August 2017 issue of *Regional Environmental Change*, Serdeczny et al. explains the human cost of climate change in sub-Saharan countries. For residents who cannot escape the heat, high temperatures have been linked to an increased rate of heat stroke and all-cause mortality [2]. Although Serdeczny et al. does not specifically consider climate-controlled housing as a potential solution to this problem, their article provides strong basis for proposing such a solution.

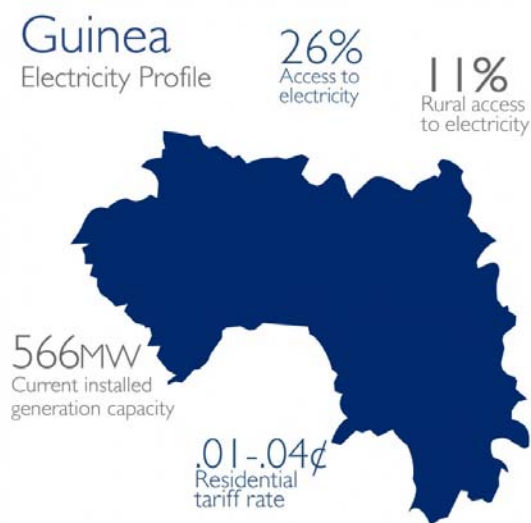

Figure 1. Map of Guinea showing percentage of households with access to electricity [3]. Rural areas, in particular, experience extremely low rates of power availability, limiting the installed generation capacity.

Unfortunately, climate control systems typically require electricity to operate; and Guinea's power grid cannot service that demand. To bring similar functionality without the huge expense of infrastructure modifications, our team has been tasked with designing a small-scale wind turbine that can generate power locally, eliminating dependency on the grid. Our turbine will not generate enough power to support a full-home HVAC system. However, it will support a rechargeable battery, which can power a portable fan in times of extreme heat. Although fans are no substitute for air conditioning, their usage increases the rate of evaporative cooling,

improving the likelihood of survival from heat stroke [4]. Our wind turbine will support this life saving technology with no additional investments in traditional infrastructure.

We expect the power output from our generator to be relatively conservative, at around 0.5 W. We designed our estimate around the average wind speed in Conakry – Guinea’s capital. In Conakry, wind speeds average 3.62 m/s [5]; and that speed produces our estimated power, even with the conservative correction factors discussed in our efficiency calculations, provided later in the proposal. For the meantime, we will assume that Conakry has adequate wind speeds to produce the necessary power. Even though 0.5 W does not provide much overhead for recharging our fan batteries, the voltage required for these cells adheres to low requirements [6]. In addition, the cells can still charge, albeit more slowly, in times of low wind.

Proposed Design for Small-Scale Wind Turbine

This document proposes a design for a small-scale wind turbine that could be used to recharge portable fans for households in Conakry, Guinea. The fan will help residents in Guinea reduce the health risks associated with rising temperatures, such as heat exhaustion or heat stroke. When designing the turbine, we assumed that it will generate approximately 0.5 W of electrical power. Our estimated output was determined from the capabilities of our Mabuchi Motors RF-370CA DC generator, provided to us by the Mechanical Engineering Department of Penn State. We also assumed that the turbine will be mounted above the laminar boundary layer during operation, allowing it to take advantage of the maximum windspeed in a particular location. Since portability and ease of installation were critical, we constrained the overall size of our device to a 2 ft³ volume, and the overall cost of its materials will not exceed \$20.

In addition to these self-imposed constraints, our design faces two limitations that were pre-determined. First, our DC motor cannot produce more than 1 W without major modifications. Since we do not plan to make those sorts of modifications, our power output remains inherently limited. Second, our material resources are constrained by the project requirements, as published by our department. In the final iteration, our turbine must contain at least one 3D-printed part and one machined part. Thankfully, these pre-determined limitations do not pose a major threat to our creativity. Nonetheless, each limitation must be considered. In the following subsections, we will address those limitations, alongside different aspects of our design process. First, we will discuss the customer needs and specifications that we established for our small-scale wind turbine.

Customer Needs and Accompanying Metrics and Specifications

For this project, our design team was given three customer needs: power, durability, and aesthetics. Our wind turbine must produce enough power to provide electricity to people in developing countries who lack this fundamental need. It must be durable enough to function properly in high winds, and it needs to be aesthetically pleasing. The metrics used to capture

these customer needs include electrical output, height, blade length, survival of a leaf blower test, number of visible parts, material cost, and noise output. As seen in Table 1, each customer need is accompanied by an appropriate and measurable characteristic within our design. From these characteristics, we defined the specifications that our wind turbine must meet in order to satisfy the given needs.

The target values established are as follows. Our wind turbine is to produce a power output of at least 0.2 watts. We will measure the power output by placing our wind turbine in front of a traditional box fan and recording the voltage drop across several known resistors. The durability of the wind turbine will be tested using a leaf blower to simulate high wind conditions that the turbine must withstand for at least thirteen seconds. In order to be aesthetically pleasing, our team decided to minimize the height of the turbine so it is no taller than two feet, minimize the blade length so it does not exceed 1.5 ft, and minimize the number of parts to five. The cost of material is limited to \$20 and will be used to quantify how cost-effective our wind turbine design proves to be. In order to determine if our wind turbine is quiet enough, we will measure the noise output and make sure that it does not exceed 40 dB. Presented in the next subsection is the function structure and system decomposition of our small-scale wind turbine.

Table 1. Customer needs and accompanying metrics and specifications for wind turbine.

		Metrics						
		Electrical Output	Height	Blade Length	Survives Leaf Blower Test	Minimize Visible Parts	Material Cost	Noise Output
Customer Needs	Generate Power	X		X				
	Be Durable				X			
	Be Aesthetically Pleasing		X	X		X		
	Be Cost-Effective		X	X			X	
	Be Quiet							X
	Minimum	0.2 W	2 ft	1 ft	13 s	3	N/A	10 dB
	Maximum	1 W	2.5 ft	1.5 ft	N/A	5	20	40 dB

Function Structure and System Decomposition

During our design process we developed a functional decomposition diagram of the miniature wind turbine. Figure 2 represents the functional decomposition diagram we created for the wind turbine. We decided that the primary function for the wind turbine would be to produce electricity from wind energy. From that main function, we generated four sub-functions of the wind turbine: main structural integrity, capture wind energy, convert kinetic energy to mechanical energy, and convert mechanical energy to electrical energy.

Maintaining structural integrity impacts the wind turbine’s function of producing energy because it not only prevents the wind turbine from failing, but it also makes the wind turbine

more efficient by preventing loss of energy in the structural supports. Capturing the wind has an impact on structural integrity and on converting kinetic energy to mechanical energy because wind energy provides a force against the support structure of the wind turbine. Next, wind energy is used to be converted to kinetic energy through the blades. After the energy is captured, the next sub-function converts kinetic energy to mechanical energy. The wind turbine converts kinetic energy to mechanical energy from the rotation of the blades being transferred to the rotation of the shafts. With the use of gears, the mechanical advantage of the wind turbine can be increased, which can correlate to an increase in electrical efficiency. The conversion of mechanical energy to electrical energy is processed by the DC motor, which takes the mechanical energy of the shafts and converts it to electrical energy.

The input in the functional decomposition is air molecules pushing on the blades to be converted to kinetic energy and producing a force on the structural supports. The outputs of the system are the energy lost through vibrations and noise while converting kinetic energy to mechanical energy. Electricity and air are also outputs in the process, appearing after mechanical energy gets converted to electrical energy. The next section looks at these inputs and outputs in terms of potential designs.

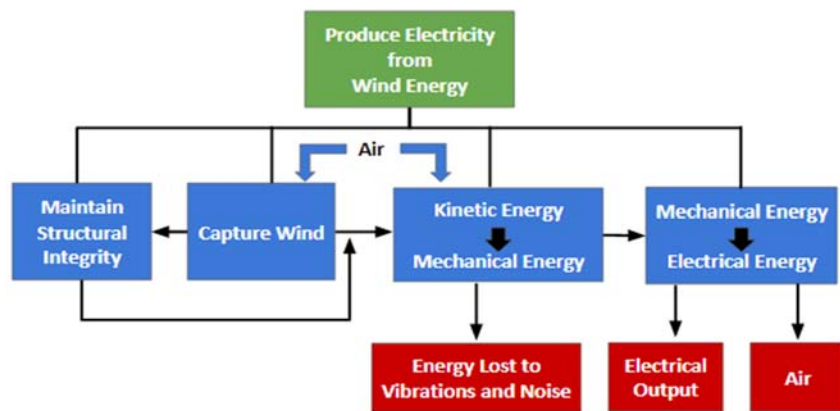

Figure 2. Functional decomposition of the small-scale wind turbine. By breaking down the main function into four sub-functions, we learned that structural integrity has a major impact on capturing wind and producing electricity. For example, if the wind turbine is not structurally stable it would show energy losses due to vibrations through the structure.

Concept Generation

To generate design concepts, our team established methods of concept generation to develop new ideas for our wind turbine. From our system decomposition, which was discussed in the previous section, our team came up with the following four sub-functions: capture wind energy, convert kinetic energy to mechanical energy, convert mechanical energy to electrical energy, and maintain structural integrity. We used these four sub-functions as a starting point for our concept generation.

The first method our team used to generate new concepts was called brainstorming. In this method for generating ideas, each team member individually tried to connect our goals and sub-goals to the resources that we had to accomplish them, using what is called the solution space. An example of one team member's brainstorming process is shown in Figure 3 to better illustrate how this method works. From this process, our team thought of different power transmission options, such as a gearbox or pulley system. We determined different ways to manufacture some of the components of our turbine, as well as some of the materials we thought would work best for those components.

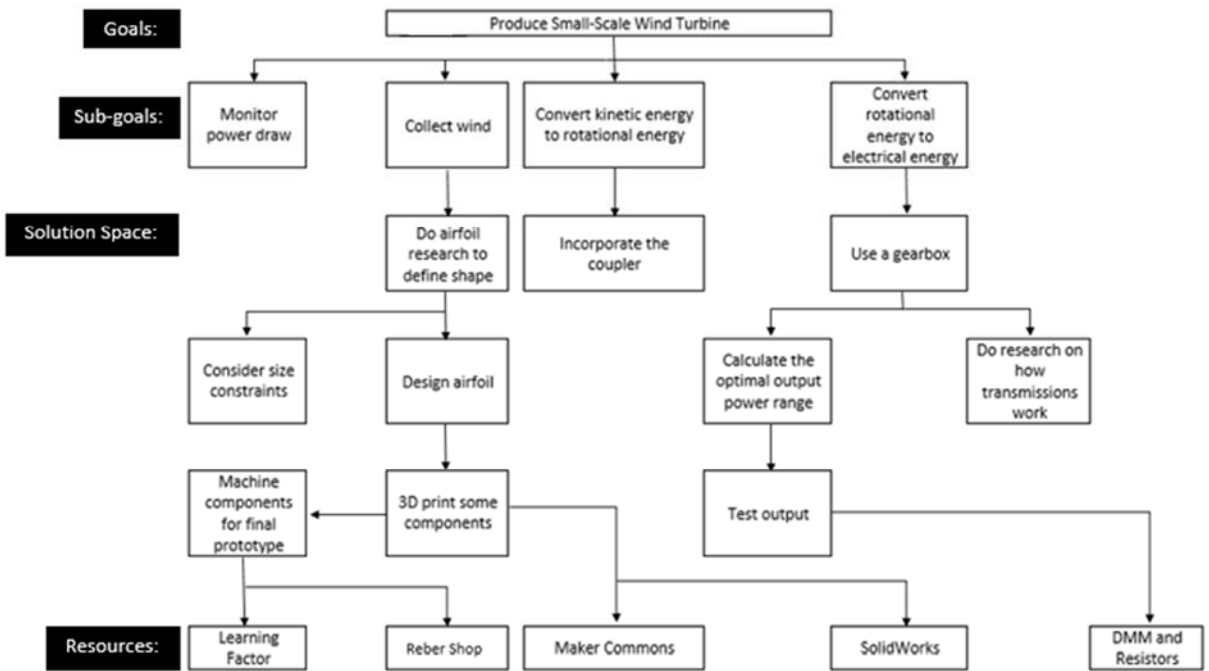

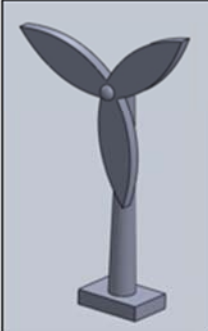

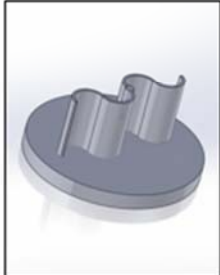

Figure 3. Example brainstorming process from one of our team members. Arrows link related objectives within the sub-function, allowing the designer to plan parts around available resources.

Another method our team used to generate new concepts was the 6-3-5 method. Since there are only three members in our team, only three sub-functions were discussed. That being said, each member of our team focused on one of the four sub-functions, and then through a rotation process, every other member of the team added her or his own ideas based on what had already been stated. Through this process, we generated several different design concepts for each sub-function. For the structural integrity sub-function, we had considered building a single cylindrical post out of different materials, building a lattice structure to support the blades and motor, and mounting the wind turbine directly to a building. When talking about converting mechanical energy to kinetic energy, our team considered using a gearbox, a pulley system, and a direct-drive transmission. When we were discussing collecting kinetic energy from the wind, we considered the number of blades, the orientation axis of our turbine, the shape of the blades

and specific airfoil designs, and the incorporation of a yaw mechanism, which would allow the housing of our turbine to rotate so that the blades always face the wind. After generating these different concepts for each sub-function, we made concept scoring matrices shown in Appendix A that allowed us to rank these concepts and decide which ones we wanted to move forward with and implement into our final concepts.

Once we had most of our ideas down on paper, and we had an idea of what sub-function concepts would work best, we decided to make rough sketches of wind turbines that would incorporate these concepts. Of these sketches, we chose five concepts that we wanted to continue developing and improving. We chose a 3-blade design with a wooden post, a 4-blade design with a metal post, a 3-blade design with a metal post and yaw, a vertical axis spline blade design, and a vertical axis cup design, all of which are illustrated in Table 2. All of the listed concepts also incorporated a gearbox into their design. To determine the best concept overall, we had designs from Table 2 undergo the screening and selection process discussed in the next subsection.

Table 2. Concepts generated for our wind turbine design.

3-Blade Wooden Post	4-Blade Metal Post	3-Blade Metal Post With Yaw	Vertical Axis Spline Blade	Vertical Axis Cup Design
				

Concept Screening and Selection

By using the concept screening matrix seen in Table 3, our team narrowed down the selection to five concepts that we wanted to further investigate. The five concepts that remained were a 3-blade design with a wooden post, a 4-blade design with a metal post, a 3-blade design with a metal post and yaw, a vertical axis spline blade design, and a vertical axis cup design. Through calculated efficiency for each blade design and gear ratio, our team was able to determine which would have the highest efficiency and produce the most power output. Our efficiency analysis was a key factor in our concept selection because the power output was weighted the highest in our AHP Matrix, which can be seen in Appendix B.

Table 3. Concept screening matrix for this design project.

Selection Criteria	Concepts				
	3 Blade Wooden Post	4 Blade Metal Post	3 Blade Metal Post With Yaw	Vertical Axis Spline Blade	Vertical Axis Cup Design
Generate Power	0	+	0	-	-
Durable	0	+	+	+	+
Aesthetically Pleasing	0	-	+	0	-
Cost-Effective	0	-	-	-	+
Quiet	0	-	-	-	-
Sum +'s	0	2	2	1	2
Sum 0's	5	0	1	1	0
Sum -'s	0	3	2	3	3
Net Score	0	-1	0	-2	-1
Rank	1	2	1	3	2
Continue?	Yes	Maybe	Yes	No	No

Next, we made a concept scoring matrix, which is illustrated in Table 4, that allowed our team to rank each wind turbine. In addition to the AHP Matrix, we also used Taguchi arrays to determine the best type of turbine to use, the target output power, and the ideal gear ratio. Our Taguchi arrays can be seen in Appendix C. Using the Taguchi analysis allowed us to justify our reasoning behind each specific score designated to every wind turbine concept. According to our Taguchi Analysis for different blade configurations, a 3-blade turbine is superior to the rest. The 4-blade is a close second, followed by a 2-blade turbine. As shown in our analysis, we did not include the vertical wind turbine concepts from our concept generation phase. The omission of this analysis is simply because we did not have enough data to calculate the efficiency of a vertical axis wind turbine. Therefore, we decided to eliminate these concepts from further consideration. The reason our 3-blade turbine with a yaw scored higher than the standard 3-blade concept was because it can face the direction of the wind, allowing it to collect more wind energy and operate more efficiently.

When deciding which concept scored higher for durability, our decision came down to the type of support structure that we had considered for each concept. If the concept being scored used a metal post, it scored higher than if it had a wooden post. Our team assumed that using aluminum or steel to support our turbine would be stronger and help minimize the vibrations from the spinning blades. For aesthetically pleasing, we scored concepts higher if they had fewer visible parts. For example, the 4-blade concept scored lower than the 3-blade because it has more blades that will obstruct our customer's view. We used similar reasoning for scoring the cost-effectiveness of each concept. If the turbine has more blades, it will cost more to make, which will cause that concept to be less cost-effective. When deciding how to score each concept for noise output, we assumed that having more blades would produce higher noise output. For this reason, the 4-blade turbine scored lower in this category than the 3-blade.

After each concept was rated against the customer needs, the weighted scores were summed together to give a total score for each concept. The weighted scores were used to rank each concept and determine which one would be superior to the rest. Through this process, our team chose the 3-blade design with metal post and yaw. This concept was what we decided to move forward with and begin prototyping.

Table 4. Concept scoring matrix for the remaining design concepts.

		3 Blade Wooden Post		4 Blade Metal Post		3 Blade Metal Post With Yaw		
		Weight	Score (1-5)	Weighted Score	Score (1-5)	Weighted Score	Score (1-5)	Weighted Score
Customer Needs	Generate Power	0.365	4.000	1.460	3.000	1.095	5.000	1.824
	Durable	0.266	3.000	0.799	4.000	1.066	4.000	1.066
	Aesthetically Pleasing	0.097	3.000	0.292	2.000	0.194	3.000	0.292
	Cost-Effective	0.243	4.000	0.973	2.000	0.487	3.000	0.730
	Quiet	0.028	3.000	0.085	2.000	0.056	3.000	0.085
Total Score:			3.608		2.898		3.996	
Rank:			2		3		1	

Efficiency Calculations

To optimize the design of our wind turbine for maximum power output, we calculated the torque supplied by different blade configurations and compared that torque supplied to the torque required for a desired output from the electrical generator. In this analysis, we consider the following blade configurations, depicted in Figure 4: American (A), 4-Blade (B), 3-Blade (C), 2-Blade (D), and 1-Blade (E).



Figure 4. Five blade configurations with different torque characteristics: (A) American, (B) 4-Blade, (C) 3-Blade, (D) 2-Blade, and (E) 1-Blade. Torque models for each configuration emphasize blade count rather than geometry.

Before analyzing the torque, we needed to determine how much kinetic energy could be captured from the wind because torque supplied is dependent on the kinetic energy provided. Since kinetic energy itself is a function of velocity, we leveraged a simple test to determine the average wind speed that our small-scale turbine would experience. For testing purposes, we used a residential box fan to generate a constant air current. At nine different locations, perpendicular

to the direction of flow, we measured the air speed with an anemometer and recorded our readings. To improve the accuracy of our numbers, we incorporated additional data from our classmates, measured in the same locations with respect to the box fan, and calculated a mean value from the measurements. The combined data yielded a nominal wind speed of 2.78 m/s. In Conakry, the wind speed averages 3.62 m/s [5]; therefore, any data collected from the box fan will provide a conservative estimate of operational conditions.

Using data from the box fan, we determined the amount of the power available from the wind. In the case of a wind turbine, power (1) can be decomposed into a function of three parameters:

$$P = \frac{1}{2} \rho A U^3, \quad (1)$$

where ρ is the air density, A is the cross-sectional area swept by the blades, and U is the nominal wind speed. For the box fan, we assumed a constant air density of 1.2 kg/m³ [7]. Since the box fan measures 20" \times 20" across its surface, we selected a blade radius of 10" to maximize the swept area with respect to the fan. Using equation (1), we determined that the box fan could supply up to 2.17 W to the turbine. Unfortunately, the turbine blades cannot capture all the power supplied, since they require some airflow between the blades to operate. Applying the 0.4 correction factor suggested by David Wood, author of *Small Wind Turbines: Analysis, Design, and Application* [8], accounts for this discrepancy, yielding 0.869 W of effective power. We refine that estimate further by considering the torque produced by different blade configurations.

For each blade configuration, we looked at the rotor torque coefficient C_m versus the tip-speed ratio λ . The tip-speed ratio (2) relates turbine blade geometry to the nominal wind speed:

$$\lambda = \frac{R \omega}{U}, \quad (2)$$

where R is the blade radius, ω is the angular velocity of the blades in rad/s, and U is the nominal wind speed. We considered an operational range between 0 and 1000 RPM for the angular velocity. From the tip-speed ratio, we calculated the rotor torque coefficient for each blade configuration. Unfortunately, no theoretical relationships between the tip-speed ratio and the rotor torque coefficient exist. Instead, we relied upon the following curve fit (3) to determine the rotor torque coefficient y :

$$y = (c_4 x^4) + (c_3 x^3) + (c_2 x^2) + (c_1 x) + c_0, \quad (3)$$

where x is the tip-speed ratio and $C_{4,3,2,1,0}$ are empirical coefficients unique to each blade configuration.

The rotor torque coefficient offers a convenient way to relate the torque supplied by the wind to the torque produced by the blades. From this point forward, the blades and their connective elements will be referred to as the rotor. To find the torque supplied by the rotor (4), defined as T_{rotor_S} we can leverage the following relationship:

$$T_{rotor_S} = C_m \frac{1}{2} \rho A R U^2, \quad (4)$$

where C_m is the rotor torque coefficient and ρ , A , R , and U are the parameters defined in (1) and (2). Leveraging the relationship between power and torque, while adjusting for efficiency, we see that the torque required at the generator (5), designated as T_{gen} , can be expressed as follows:

$$T_{gen} = \frac{P_{out}}{\omega_{gen}\eta_{gen}}, \quad (5)$$

where P_{out} is the desired power output from the generator, ω_{gen} is the angular velocity of the generator in rad/s, and η_{gen} is the efficiency of the motor. Although this relationship appears relatively straightforward, interdependency between the parameters complicates the analysis. For instance, the generator efficiency is not constant, but varies with angular speed. Moreover, if a gear ratio is implemented between the input shaft and the generator, the angular velocity of the generator no longer equals the angular velocity of the rotor. Taking these factors into account, the torque needed at the rotor (6), denoted as T_{rotor_N} , becomes

$$T_{rotor_N} = \frac{P_{out}}{\omega_{rotor}\eta_{gen}}. \quad (6)$$

If we plot the torque supplied by the rotor and the torque required at the generator versus the angular velocity of the rotor, the region of intersection between the two curves represents the operating range for the wind turbine with a given set of input parameters. Using the Taguchi method of parameter variation, discussed in the Appendix C, we strategically tested different combinations of input parameters. In our analysis, we varied the following three parameters: blade configuration, gear ratio, and output power. We did not vary the blade radius ($R=10''$) since this variable was already optimized for the size of the box fan. Our analysis revealed a point of maximum efficiency between 300 RPM to 500 RPM. Within this range, the Taguchi method selected a 3-blade configuration with a 3:1 gear ratio, operating at 0.5 W. Figure 5 shows the torque curves for this configuration.

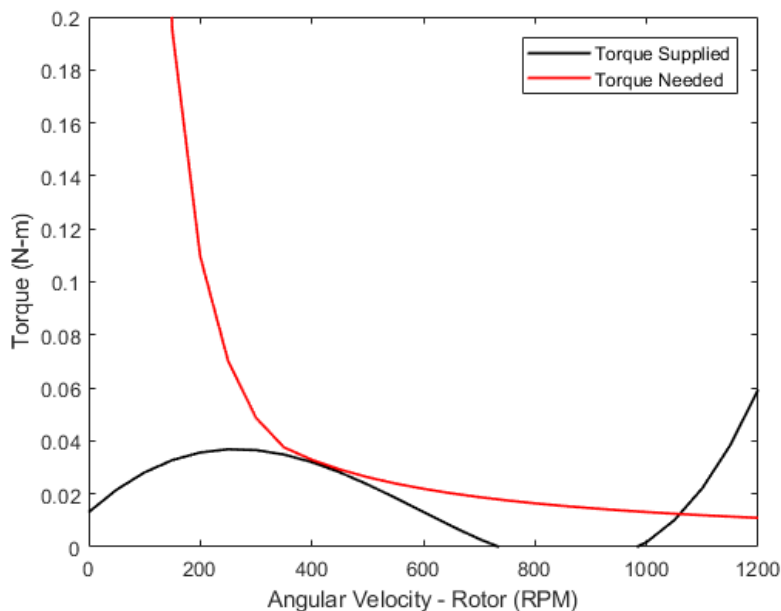

Figure 5. Torque output versus angular velocity for a 3-blade configuration with a 3:1 gear ratio, operating at 0.5 W. Maximum efficiency occurs between 300 RPM to 500 RPM, where the two curves overlap.

Management Plan

With the concept screening and selection process complete, we will start developing our Alpha I prototype based on the parameters selected. Our selected design, a 3-blade turbine with metal stand and yaw control, will require multiple parts and manufacturing techniques, even at the prototype level. Since our budget is only \$20, we cannot afford delays in the prototyping process. To avoid delays, we divided our project into phases and developed specific objectives for each phase. Appendix D includes the most detailed version of this schedule; it includes all task assignments for every phase of the project and accounts for potential interference between those tasks. Unfortunately, the amount of detail dedicated to each phase makes it difficult to identify major milestones in the project. Figure 6 isolates those phases from their sub-tasks, making it easier to identify major milestones. Although Figure 6 is dramatically simplified, the color of each phase on the diagram maintains parity with Appendix D.



Figure 6. Major phases in the project. Appendix C contains a more detailed schedule, which breaks down each phase into assignable tasks.

From Figure 6, our project can be divided into five major phases: Proposal, Alpha I, Alpha II, Beta, and Final Report. Both the proposal section and the final report contain a presentation element that runs parallel to the primary milestone. However, for the rest of this section, that presentation element will be merged with its primary milestone, leaving five phases to discuss. Since the proposal phase has already been completed, that phase will also be omitted from this discussion. Starting with the Alpha I prototype, we will focus on the form and structure of the design. We will not bother with precise construction or power optimizations, focusing on the overall design rather than the details of each component. In Alpha II, we will start to improve the individual components and increase their durability. During this iteration, we will also increase our overall efficiency by implementing a gear reduction. For our Beta prototype, we will continue to improve the tolerances on our components and integrate waterproofing measures into the housing. We will also explore yaw functionality within the stand, adding additional optimizations for wind-capture efficiency. All three prototypes will culminate in a final presentation and formal report, delivered on April 24 and submitted for review by April 27.

To meet our proposed schedule, each member of the team will assume distinct responsibilities that can be completed simultaneously. For every prototype, Sam Bonner will design

the enclosure for powertrain components. Her SolidWorks skills and additive manufacturing experience make her uniquely qualified for that role. While Sam works on the enclosure, Devon Heston will be responsible for the powertrain design and part selection. His studies in Machine Design give him the necessary background for this part of the project. Working closely with Sam and Devon, Pei Chan will handle the blade design and support structure. His detail-oriented design skills will be invaluable for those components.

Appendix A: Concept Scoring Matrices by Sub-Function

During concept generation, we focused on the following three sub-functions: blade design, gear design, and structure design. For each sub-function, we selected six concepts and ranked them according to our customer needs. We weighted power production and durability as the most important, ranking our concepts according those priorities. Tables A-1 through A-3 summarize the results of our concept scoring process for each sub-function. We will pursue the 3D Printed Airfoil Blades and PVC Curved Blade Design, the Metal Helical Gears and Metal Pulley Gear System, and the Metal Post and Wooden Cone Support Mount.

Table A-1. Concept scoring for the blade design sub-group.

		Blade Design												
		3D Printed Cups		3D Printed Turbine Blades (Windmill Shaped)		3D Printed Airfoil Blades		PVC Curved Blade Design		Metal Wedge Shaped Blades		Wooden Airfoil Design		
		Weight	Score (1-5)	Weighted Score	Score (1-5)	Weighted Score	Score (1-5)	Weighted Score	Score (1-5)	Weighted Score	Score (1-5)	Weighted Score	Score (1-5)	Weighted Score
Customer Needs	Generate Power	0.365	2.000	0.730	3.000	1.095	4.000	1.460	4.000	1.460	4.000	1.460	4.000	1.460
	Durable	0.266	3.000	0.798	3.000	0.798	3.000	0.798	4.000	1.064	5.000	1.330	4.000	1.064
	Aesthetically Pleasing	0.097	2.000	0.194	2.000	0.194	3.000	0.291	2.000	0.194	2.000	0.194	2.000	0.194
	Cost-Effective	0.243	4.000	0.972	4.000	0.972	4.000	0.972	3.000	0.729	1.000	0.243	2.000	0.486
	Quiet	0.031	3.000	0.093	3.000	0.093	3.000	0.093	2.000	0.062	2.000	0.062	3.000	0.093
	Total Score:			2.787		3.152		3.614		3.509		3.289		3.297
Rank:			6		5		1		2		4		3	

Table A-2. Concept scoring for the gear design sub-group.

		Gear Design												
		No Gears		Metal Spur Gears		Metal Helical Gear		Metal Pulley Gear System		Acrylic Spur Gears		3D Printed Spur Gears		
		Weight	Score (1-5)	Weighted Score	Score (1-5)	Weighted Score	Score (1-5)	Weighted Score	Score (1-5)	Weighted Score	Score (1-5)	Weighted Score	Score (1-5)	Weighted Score
Customer Needs	Generate Power	0.365	2.000	0.730	3.000	1.095	4.000	1.460	4.000	1.460	3.000	1.095	3.000	1.095
	Durable	0.266	3.000	0.798	5.000	1.330	5.000	1.330	5.000	1.330	1.000	0.266	4.000	1.064
	Aesthetically Pleasing	0.097	3.000	0.291	3.000	0.291	3.000	0.291	2.000	0.194	4.000	0.388	3.000	0.291
	Cost-Effective	0.243	5.000	1.215	2.000	0.486	2.000	0.486	2.000	0.486	4.000	0.972	2.000	0.486
	Quiet	0.031	5.000	0.155	3.000	0.093	3.000	0.093	2.000	0.062	3.000	0.093	3.000	0.093
	Total Score:			3.189		3.295		3.660		3.532		2.814		3.029
Rank:			4		3		1		2		6		5	

Table A-3. Concept scoring for the gear design sub-group.

		Structure Design												
		Wooden Post		3D Printed Cage with Triangular Supports		Lego Support Structure		Wooden Cone Support Mount		Metal Post		Triangular Wooden Post		
		Score (1-5)	Weighted Score	Score (1-5)	Weighted Score	Score (1-5)	Weighted Score	Score (1-5)	Weighted Score	Score (1-5)	Weighted Score	Score (1-5)	Weighted Score	
Customer Needs	Weight													
	Generate Power	0.365	3.000	1.095	3.000	1.095	3.000	1.095	3.000	1.095	4.000	1.460	3.000	1.095
	Durable	0.266	3.000	0.798	3.000	0.798	2.000	0.532	4.000	1.064	5.000	1.330	3.000	0.798
	Aesthetically Pleasing	0.097	3.000	0.291	1.000	0.097	2.000	0.194	3.000	0.291	3.000	0.291	2.000	0.194
	Cost-Effective	0.243	4.000	0.972	3.000	0.729	3.000	0.729	3.000	0.729	2.000	0.486	3.000	0.729
	Quiet	0.031	4.000	0.124	2.000	0.062	3.000	0.093	4.000	0.124	4.000	0.124	3.000	0.093
Total Score:		3.280		2.781		2.643		3.303		3.691		2.909		
Rank:		3		5		6		2		1		4		

Appendix B: AHP Matrix

In this appendix, our team presents our Analytical Hierarchy Process (AHP) matrix that determined how much weight each customer need had relative to each other. As shown in Table B-1, the need for our turbine to generate power weights the highest against all other customer needs. Durability was our next highest weighted customer need. It was rated more important than all other customer needs except generating power. Like before, if our turbine is not durable and needs to be fixed all the time, it will not be cost-effective or be able function the way it was intended to. The need for our turbine to be cost-effective is weighted third because our turbine needs to be affordable to the citizens of Guinea, who do not have an extensive amount of money. Our last two customer needs, to be aesthetically pleasing and quiet, have very low weights compared with the other needs of our turbine. Both of these needs do not contribute to the power output or the structural integrity of our wind turbine, which is why we decided to rate them less than all the other customer needs.

Table B-1. Our team’s Analytical Hierarchy Process (AHP) matrix for our design proposal.

	Generate Power	Durable	Aesthetically Pleasing	Cost-Effective	Quiet	Normalized Total	Weight
Generate Power	1.00	3.00	7.00	2.00	8.00	21.00	0.365
Durable	0.33	1.00	5.00	2.00	7.00	15.33	0.266
Aesthetically Pleasing	0.14	0.20	1.00	0.25	4.00	5.59	0.097
Cost-Effective	0.50	0.50	4.00	1.00	8.00	14.00	0.243
Quiet	0.13	0.13	0.25	0.13	1.00	1.63	0.028
					Total	57.55	1.000

Appendix C: Taguchi Analysis

To determine the point of maximum efficiency for our design, we performed a Taguchi analysis on the following three parameters: turbine type, output power, and gear ratio. Following the methods proposed by Professor John Cimbala [9], we developed a Taguchi array that varies each parameter along five levels. Combining three parameters with five levels of variation strategically tests twenty-five different combinations of those parameters. In contrast, a full-factorial experiment would require 125 different experiments to gain the same amount of information [9]. Clearly, the Taguchi analysis offers substantial time-savings over a full-factorial experiment.

For the analysis, we looked at the difference between the torque needed for a given power and the torque supplied by the turbine blades. Further explanation of this technique and the calculations involved can be found under Efficiency Calculations. To quantize the difference between torque needed and torque supplied, we calculated the area between the two torque curves within the operational range of our turbine (350 RPM to 500 RPM). The smaller the area, the closer the two curves. Closely matched curves within the operational range translates to higher efficiency overall. Once the area was determined for each permutation, we performed level averages across each parameter and plotted the results. Figures C-1 through C-3 summarize the results. For each plot, locating the minimum area indicates the point of maximum efficiency for that parameter.

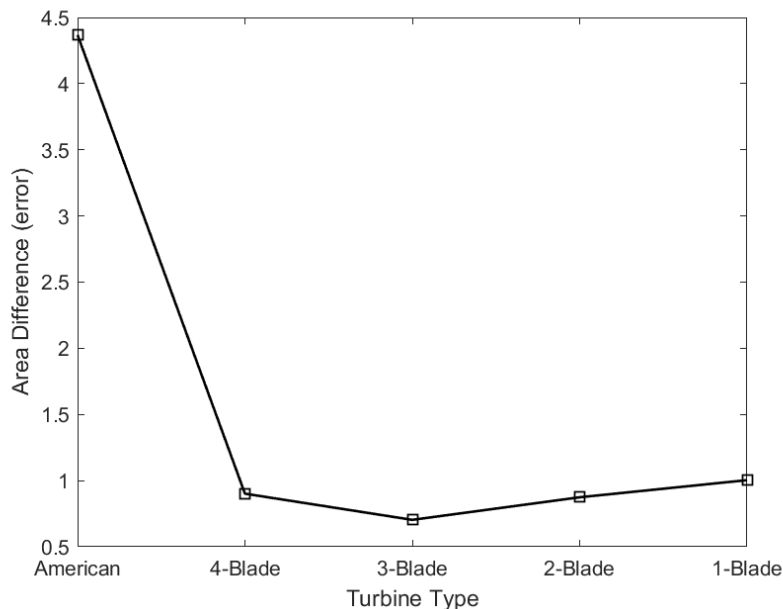

Figure C-1. Level averages for each blade configuration. A 3-Blade configuration minimizes the difference in area between the torque needed and the torque supplied, maximizing efficiency.

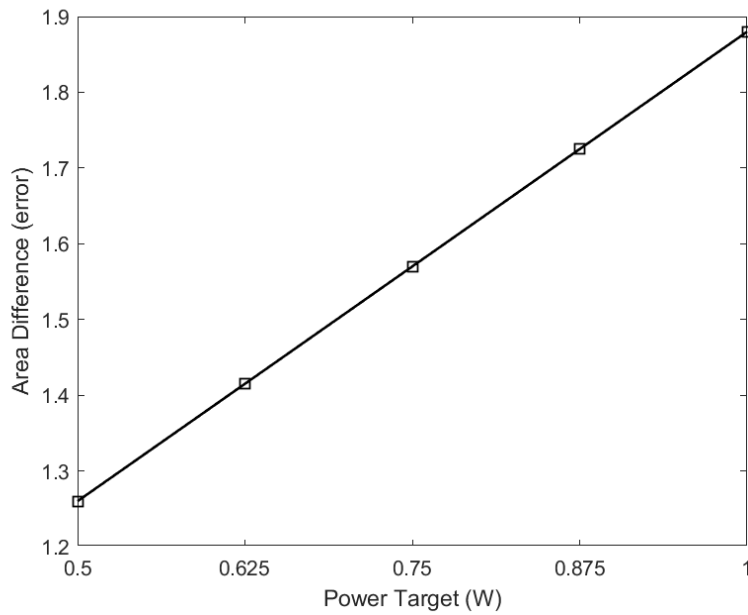

Figure C-2. Level averages for power produced. Producing less power results in higher efficiency, since the torque required and the torque supplied are more closely matched.

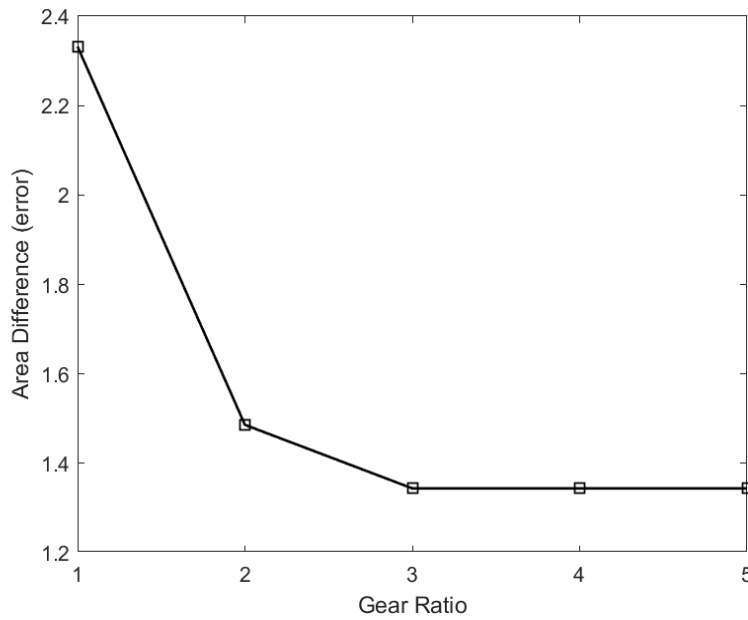

Figure C-3. Level averages for different gear ratios. After 3:1, higher gear ratios see diminishing returns on efficiency, indicated by the zero slope between level averages.

Appendix D: Detailed Management Plan

Figure D-1 shows the full-length management plan for our project. Major project phases are outlined in black and highlighted in the title bar. To improve readability, each phase and its sub-tasks are color-coded.

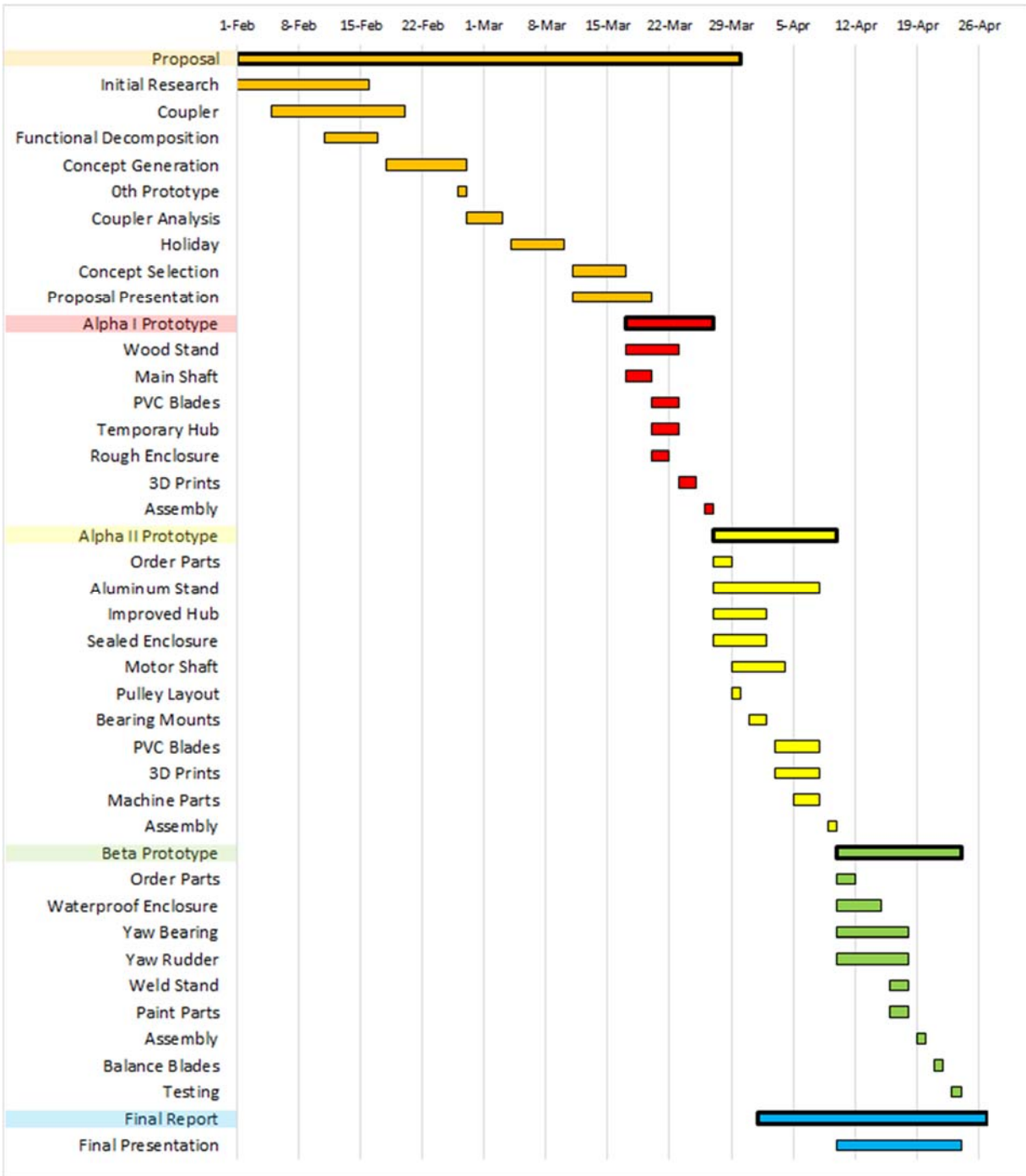

Figure D-1. Full-length management plan for our project. Color-matched bars indicate different phases.

References

- [1] *Treehugger*. Air Breeze. 30 Sep. 2008, <https://www.treehugger.com/renewable-energy/air-breeze-a-teeny-tiny-turbine-for-off-grid-power.html>. Accessed 30 Mar. 2018
- [2] Serdeczny, Olivia, et al. "Climate Change Impacts in Sub-Saharan Africa: From Physical Changes to Their Social Repercussions." *Regional Environmental Change*, vol. 17, no. 6, 2016, pp. 1585–1600., doi:10.1007/s10113-015-0910-2.
- [3] "Guinea: Power Africa Fact Sheet." USAID, USAID, 8 Feb. 2018, www.usaid.gov/powerafrica/guinea.
- [4] Gaudio, Flavio G., and Colin K. Grissom. "Cooling Methods in Heat Stroke." *Journal of Emergency Medicine*, vol. 50, no. 4, 2016, pp. 607-616.
- [5] "Global Climate Station Summaries Map." *National Centers for Environmental Information*, National Oceanic and Atmospheric Administration, gis.ncdc.noaa.gov/maps/ncei/summaries/global.
- [6] "Energizer NH15-2300 (HR6)." Energizer. <http://data.energizer.com/pdfs/nh15-2300.pdf>.
- [7] Çengel, Yunus A., and John M. Cimbala. *Fluid Mechanics: Fundamentals and Applications*. McGraw-Hill Education, New York, NY, 2018.
- [8] Wood, David, and SpringerLink (Online service). *Small Wind Turbines: Analysis, Design, and Application*. Springer-Verlag London Limited, London, 2011
- [9] Cimbala, John. "Taguchi Orthogonal Arrays." Penn State University, 17 Sept. 2014. http://www.mne.psu.edu/cimbala/me345/Lectures/Taguchi_orthogonal_arrays.pdf.